

REMS reciprocating saws Legend

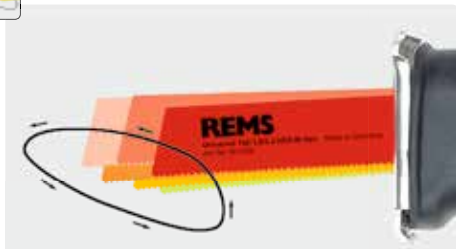

Aggressive orbital action by vertical hacking motion of saw blade provides forceful, fast forward feed, excellent chip flow and long service life of saw blades.

Fixed orbital action, running in needle bearings, ensures long-lasting and forceful sawing also during extreme load conditions, e.g. sawing of steel pipe. Adjustable mechanisms with a great variety of parts and a reduced system stability do not withstand the high in-feed pressure and the heavy-duty requirements of forceful cutting of steel pipes, particularly when a guide support with leverage is being used.



Sturdy, square lift rod in special solid steel, mounted precisely in needle bearings towards the force direction and along the complete stroke length, for distortion-free, precise cutting also during tough use and by applying multiple sawing force, e.g. using a guide support with leverage. For extremely long service life.

Special high sliding silicone gasket protects gear against water and dust.

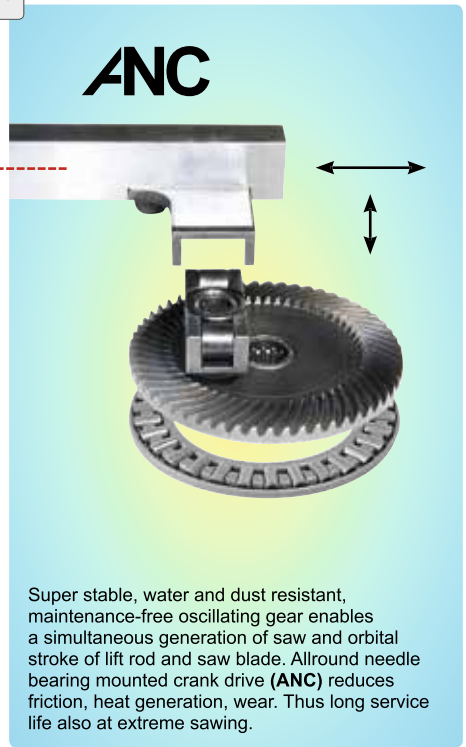

Super stable, water and dust resistant, maintenance-free oscillating gear enables a simultaneous generation of saw and orbital stroke of lift rod and saw blade. Allround needle bearing mounted crank drive (ANC) reduces friction, heat generation, wear. Thus long service life also at extreme sawing.

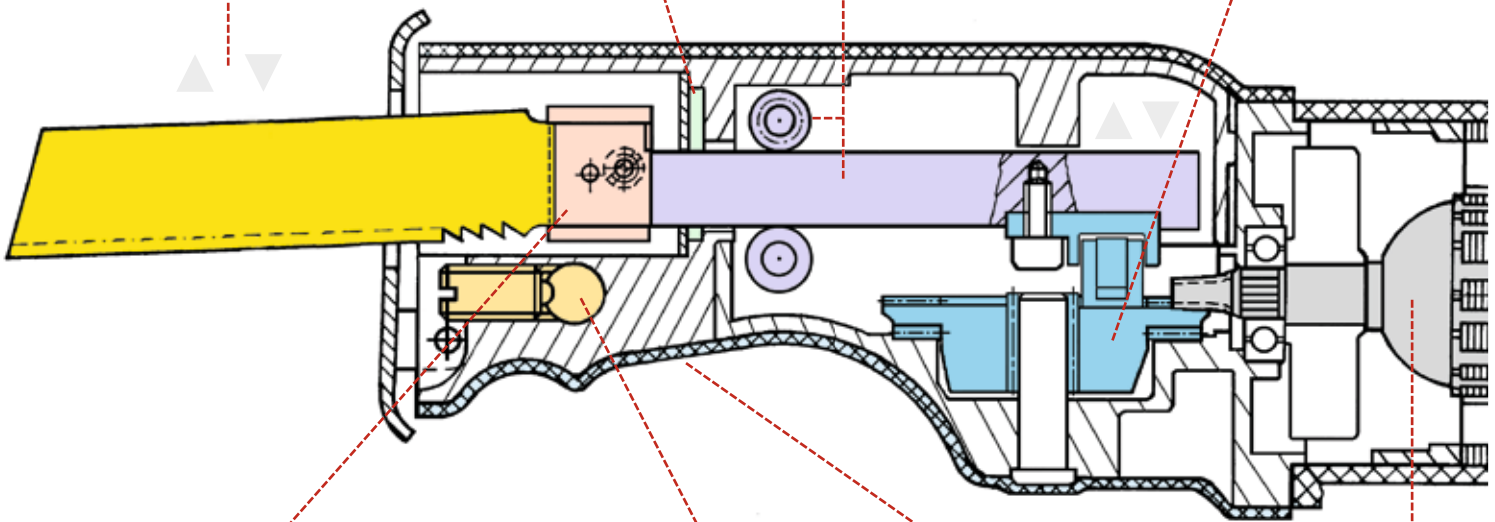

Universal saw blade clamp for mounting all saw blades – with universal or double tang – without changing or turning the saw blade thrust piece.



Guide support for 400 % additional sawing force for fast, effortless sawing. Also for effortless demolition work.

V/bar
Drive motors
230 V, 110 V, 48 V,
22 V, 6 bar

Ergonomically shaped front housing grip with slip resistant protection cover, for forceful feed forward while sawing free-hand.



Vario-Electronic

Electronic stepless speed control of drive unit for sensitive start-sawing and for stroke selection during sawing according to the material. The stroke speed is controlled continuously by variable pressure on the touch switch from 0 to 2,800 rpm (REMS Puma VE), 0 to 2,400 rpm (REMS Cat ANC VE, REMS Tiger ANC VE) or 0 to 2,000 rpm (REMS Akku-Cat 22 V ANC VE) (accelerator switch).



Ideal speed

Deliberately fixed speed. Therefore optimum cutting speed for maximum protection of motor and gear and maximum service life of saw blades. The ideal cutting speed of 2,400 rpm has been determined by extensive sawing tests with steel pipe which lead to optimum performance in combination with the aggressive, fixed orbital action, guide support and REMS special saw blade.



Power-transferring guide support

For assembly and dismantling. Guide support with five-fold force transmitting leverage allows effortless, fast, right angled sawing anywhere on site, without a vice. Ideal handling, easy and rapid to operate, positioned with one hand only for chucking and sawing. No loose swinging chain and cumbersome handling as with chain vice. No danger of jamming by limitation of swing angle. 400 % additional sawing force for effortless, super fast sawing during assembly and dismantling, e.g. 2" steel pipe in only 8 s. Straight machine handle for optimum forward feed.



Speed-Regulation

Stepless electronic speed control of drive unit for selecting the speed according to the material. Ideal for sawing stainless steel pipe, cast pipe and for sawing boilers, tanks, bath tubs etc. The speed is continuously adjustable between 700 and 2,200 rpm on the dial. The electronic speed control which is being used keeps the selected speed constant, also under load, including speed generator, control electronics, residual current limitation for sensitive start-sawing, motor temperature control of field wires with PTC resistance (Positive Temperature Coefficient) and stall protection of gear and motor.



Weight

High sawing efficiency at low weight by innovative, proven technology and perfect tuning of all components. For effortless, fatigue-free sawing and easy handling.



Power

All power data stated to be understood as the rated power input. The drive motors of REMS reciprocating saws have a very high efficiency of approx. 65% thanks to an outstanding technology and quality. Therefore the user has a high power output available which is useful particularly for sawing difficult-to-cut materials, e.g. steel pipe. High power output can only be used fully by levered sawing, e.g. with the REMS guide support.



Drive Motors

Depending on model universal motors of voltages of 230 V, 110 V, 48 V, battery motors 22 V or pneumatic motors for 6 bar operating pressures are used. All drive motors are extremely powerful, fulfill highest quality demands and come with large power reserves, for long service life.



Saw blade holder with quick-change system

Practical saw blade holder with quick-change system for fast saw blade changing without tools. For holding single tang saw blades.



Continuously adjustable support shoe

Swivel support shoe for safe guiding of the saw on the material to be sawn. Support shoe continuously adjustable in longitudinal direction by 40 mm for better utilisation of partially blunted saw blades and for setting the plunge-in depth of the saw blade in the material.



Anti-vibration system

Special drive technology with mass compensation and vibration damping handles. For low vibration, effortless sawing.



Saw blade can be inserted turned 180°.

Saw blade can be inserted with the teeth facing down or turned 180° facing up for cuts in confined spaces with difficult access.