

Light, portable compact machine. Universal for cutting and deburring pipes. For trade and industry. For the building site and the workshop.

Stainless steel pipes of pressfitting systems, carbon steel, copper \varnothing 8–108 mm

Steel pipes EN 10255 (DIN 2440) DN 6–100
 \varnothing 1/8–4", \varnothing 10–115 mm

Cast iron pipes (SML) EN 877 (DIN 19522) DN 50–100

Plastic pipes SDR 11
Wall thickness $s \leq 10$ mm \varnothing 10–110 mm
 \varnothing 1/8–4"

Multilayer composite pipes \varnothing 10–110 mm

REMS Cento RF Set

Welded drain pipe/down pipe made of stainless steel (EN 1124) \varnothing 40–110 mm

REMS Cento – Cutting and deburring up to \varnothing 115 mm. Super fast. Right angled. Chip-free. No outer burr. Dry cutting.

Universal for many pipe types.

Ideal for pressfitting systems

Right angled cutting, according to requirements

Chip-free, no chips in piping system

No outer burr, no damage to O-ring by outer burr

Dry, no damage to the O-ring by coolants-lubricants.

Fast, prevents degradation of pipe material through overheating.

Design

Compact, mobile pipe cutting machine for fast, right angled, cutting with no outer burr. Handy and light, only 16.8 kg. Stable, distortion-free cast construction for right angled cutting. Easy pipe-cutting through specially designed cutter wheel. Powered cutter wheel and linear advance for fast cutting (**Patent EP 1 782 904**). Power saving feed-in through easy to grip, proven advance-lever and needle bearing mounted machine screw spindle. Cutter wheel protected – as movement restricted to before any contact with the rollers. Connection for driving outer/inner pipe deburrer REMS REG 10–54 E. For workbench, stand or wheel stand as an accessory, for easy transport, optimum working height and stable positioning. An alternative feed lever is available for operating the drive unit on the floor, see accessories.

Running rollers

4 strong hardened precision tubular steel running rollers on ball bearings for low-friction turning of the pipes \varnothing 22–115 mm, \varnothing 3/4–4" to be cut, trapezoidally arranged, replaceable. No setting work required in the whole working range \varnothing 22–115 mm. Stainless tubular steel rollers as accessory. Cutting of pipes \varnothing 8–22 mm by placing two pipe sections \varnothing 28 x 220 mm on the running rollers. REMS Cento RF with 4 sturdy polyamide rollers mounted on ball bearings, to avoid damage to the pipe surfaces, for low-friction rotation of the welded drain pipes/downpipes of stainless steel (EN 1124) \varnothing 40–110 mm to be cut; pipe guides \varnothing 75 and 110 mm prevent the pipe from becoming oval shaped.

Drive

Robust gear, precisely mounted in roller and needle bearings, maintenance-free. Proven universal motor, 1200 W. Powerful, e.g. stainless steel pipe \varnothing 54 mm in just 4 s. Ideal speed 115 rpm for optimum cutting speed of the pipes. Safety foot-switch with emergency stop.

REMS cutter wheels

Top German quality. Cutter wheels specially designed to the performance capability of the REMS Cento and for numerous pipe materials with variable cutting geometries for fast cutting with no outer burr. Specially hardened, from proven, through-hardened REMS die-steel, ensuring long service life.

Pipe support

Pipe support, height adjustable, for pipes \varnothing 40–110 mm, \varnothing 1/2–4", with operation of the drive unit with feed lever on the floor. Easy moving of the material in all directions when turning, pulling and pushing by four stainless steel balls mounted in a rust-protected housing. Safe guiding of long pipes by use of several pipe supports.

REMS pipe deburrer

Inner pipe deburrer REMS REG 28–108 for pipes \varnothing 28–108 mm, \varnothing 3/4–4", with circulating friction element on the deburrer housing (**Patent EP 2 500 122**) for electrical rotary drive by the cutting wheel of the REMS Cento. REMS Akku-Cento 22 V pipe cutting machine, as an accessory. Outer/inner pipe deburrer REMS REG 10–54 E for pipes \varnothing 10–54 mm, \varnothing 1/2–2 1/8", for electric drive with the REMS Cento, REMS Akku-Cento 22 V pipe cutting machines, see page 97.

Marking device

Marking device for marking the insertion depth for fittings on pipes, as an accessory.

Patent EP 1 782 904



Tested by electrosuisse >>>

German Quality Product



Info

Supply format

REMS Cento Basic. Pipe cutting machine for fast, right angled, cutting of pipes with no outer burr Ø 8–115 mm. For pipes of the press fitting systems made from stainless steel, carbon steel, copper, Ø 8–108 mm. For steel pipes EN 10255 (DIN 2440) DN 6–100, Ø ½–4", Ø 10–115 mm, cast pipes (SML) EN 877 (DIN 19522) DN 50–100, plastic tubes SDR 11, wall thickness $s \leq 10$ mm, Ø 10–110 mm, Ø ½–4", composite tubes Ø 10–110 mm. With maintenance-free gear, proven universal motor 230 V or 110 V, 50–60 Hz, 1200 W. Speed 115 rpm. Rollers in hardened precision steel pipe for pipes Ø 22–115 mm, Ø ¾–4". Safety foot-switch. Ring spanner. Without cutter wheel. For workbench, stand or wheel stand. In a carton.

	Art.-No.	
	845001	

Other voltages on request.



Supply format

REMS Cento RF Set. Pipe cutting machine especially for fast, right-angled cutting of welded drain pipes/down pipes made of stainless steel (EN 1124) Ø 40–110 mm. As Art. No. 845001, but with rollers made of polyamide and pipe guides Ø 75 and 110 mm. Safety foot switch. Ring spanner. With cutting wheel RF. For workbench, stand or wheel stand. In a carton.

	Art.-No.	
	845003	

Other voltages on request.



Accessories

Description	Art.-No.	
Feed lever with spring plug for operating the drive unit on the floor (for drive units manufactured from 2014 onwards).	845218	
REMS cutter wheel Cu-INOX for stainless steel pipes of pressfitting systems, copper, carbon steel	845050	
REMS cutter wheel Cu specially for pipes of copper pressfitting systems	845053	
REMS cutter wheel St for steel pipes, cast iron pipes (SML)	845052	
REMS cutter wheel V for plastic and multilayer composite pipes, wall thickness $s \leq 10$ mm	845051	
REMS cutting wheel C-SF especially for pipes of the pressfitting systems and push fitting systems made from carbon steel, simultaneously produces a chamfer.	845055	
REMS cutting wheel RF for cutting welded drain pipes/down pipes made of stainless steel (EN 1124) with REMS Cento RF.	845054	
Pipe support 1 , height adjustable, for pipes Ø 40–110 mm, Ø 1½–4", with operation of the drive unit with feed lever on the floor	845220	
Hardened, precision tubular steel rollers (pack of 4)	845118	
Stainless tubular steel INOX rollers (pack of 4)	845110	
Polyamide roller (pack of 4)	845131	
Marking device for marking the insertion depth for fittings on pipes. For REMS Cento, REMS Akku-Cento 22V.	845530	
REMS REG 10–54 E , outer/inner pipe deburrer, see page 97		
REMS REG 28–108 , inner pipe deburrer for pipes Ø 28–108 mm, Ø ¾–4", for electric rotary drive by the cutting wheel of the REMS Cento, REMS Akku-Cento 22V pipe cutting machine (with REMS cutting wheel Art. No. 845050 or 845053).	113840	
Stand	849315	
Wheel stand	849310	
REMS Jumbo , folding workbenches, see page 103.		
REMS Herkules , material supports, see page 104.		

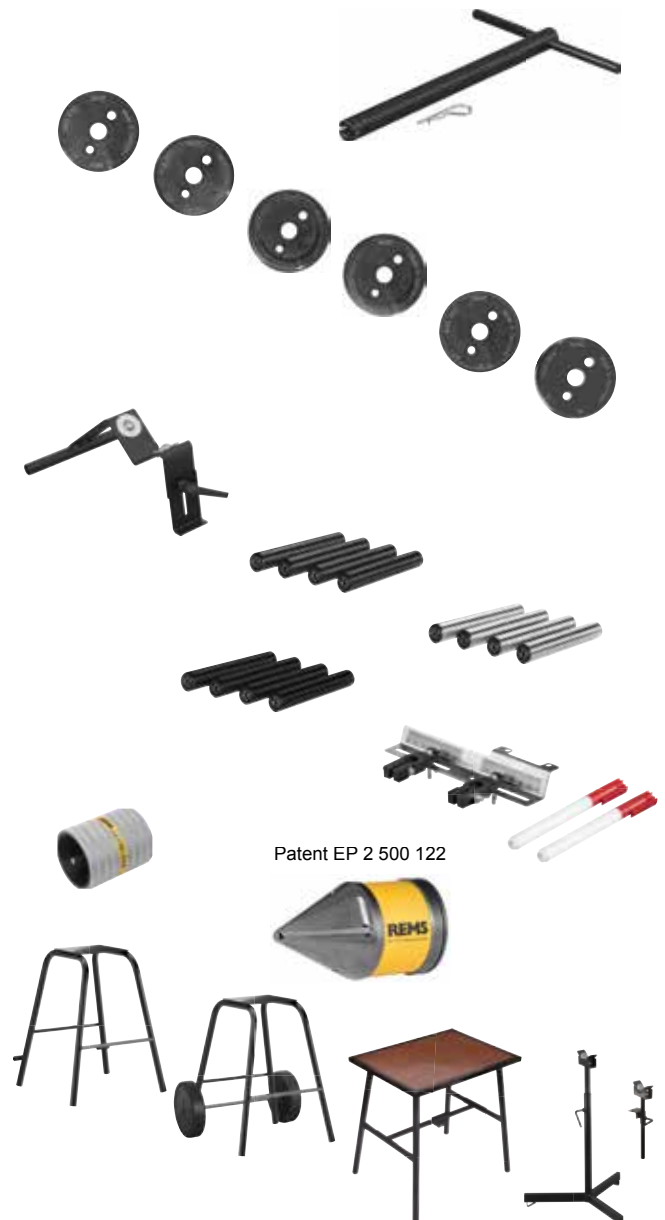

Patent EP 2 500 122