

Universal, manual radial press for producing pipe pressing joints for common pressfitting systems.

Pressing joints with plastic and multi-layer composite tubes \varnothing 10–26 mm
 \varnothing $\frac{3}{8}$ –1"

Complete range of REMS pressing tongs/pressing rings for all common pressfitting systems, see page 198–238.

REMS Eco-Press – universal up to \varnothing 26 mm. Secure crimping in seconds.

System advantage

Only **one** type of pressing tongs/pressing rings for all REMS radial presses 32 kN and suitable radial presses of other makes with 32 kN thrust force.

All pressing tongs marked with * have another connection and also fit the manual radial press REMS Eco-Press. All pressing rings S (PR-2B) marked with ** can also be driven with the manual radial press REMS Eco-Press using the adapter tong Z8.

Pressing tongs/pressing rings for all common systems

Complete assortment of REMS pressing tongs/pressing rings for all common pressfitting systems (page 198–238). Highly durable pressing tongs/pressing rings made of tenacious, specially hardened special steel. Pressing contours of REMS pressing tongs/pressing rings are system-specific and correspond to the respective pressfitting system. Thus perfect system conformity, safe press jointing. For driving the REMS pressing rings S (PR-2B) adapter tongs Z8 are required, see page 238.

Design

Compact, handy, light. Drive unit with short tubular arms only 1.6 kg. Works anywhere, free-hand, overhead, in confined areas. Secure seating of pressing tongs through locking pins. Dividable tubular arms for individual adjustment of leverage to accommodate different force demands of different pressfitting systems.

Pressing operation

A perfect joint is achieved when pressing tongs close completely. Final-lock-positioning, the pressing jaws remain in a closed position until opening. This way, the perfect pressing joint (completely closed pressing jaws) can be observed.

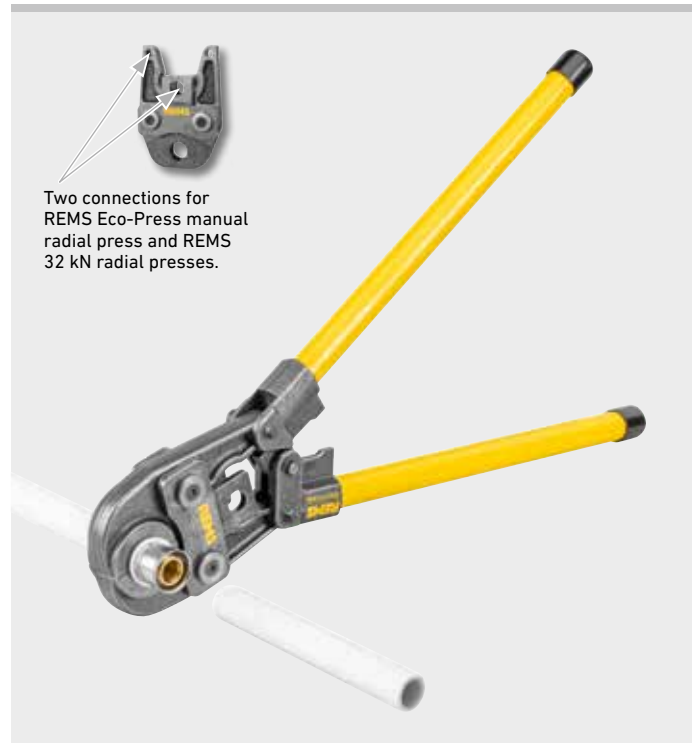

Two connections for REMS Eco-Press manual radial press and REMS 32 kN radial presses.

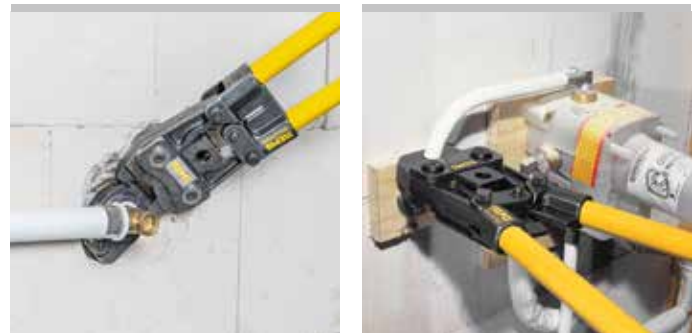

German Quality Product



Info

Supply format

REMS Eco-Press drive unit. Manual radial press with final-lock-positioning for producing pressing joints of plastic and multi-layer composite tubes \varnothing 10–26 mm, \varnothing $\frac{3}{8}$ –1". For driving REMS pressing tongs/pressing rings. With dividable tubular arms. In skin package.

	Art.-No.	лв.
	574000R	445,00



Accessories

Description	Art.-No.	лв.
REMS pressing tongs/pressing rings , see page 198–238.		
Adapter tongs Z8 for driving REMS pressing rings S (PR-2B)	574702R	283,00
REMS cropping tongs for threaded rods see page 241.		
Carrying bag for drive unit and for 3 pressing tongs	574436R	75,20
Steel case with insert for drive unit and for 3 pressing tongs	574430R	189,00

